

MagnumStone Batter

>>>STANDARD

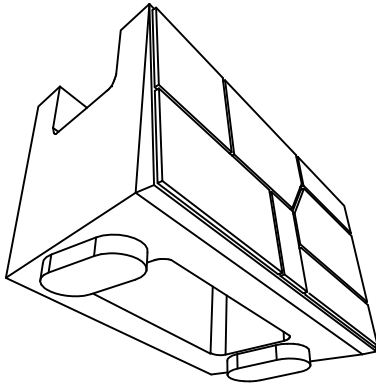

>>>ISOMETRIC BOTTOM VIEW

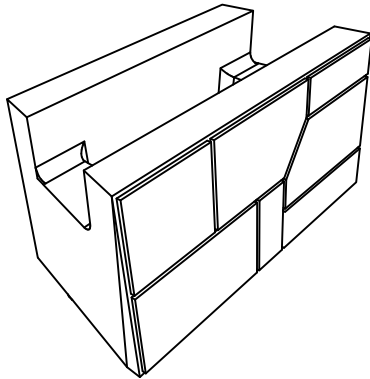
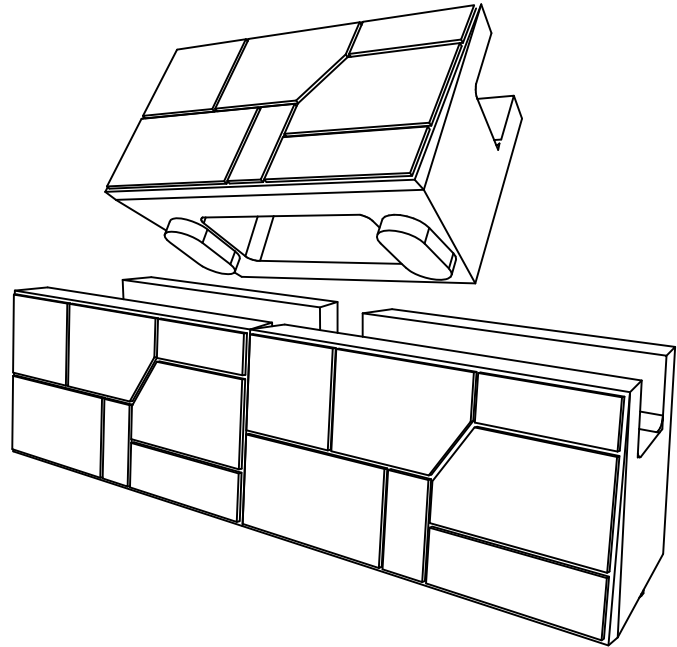

>>>ISOMETRIC TOP VIEW

Dimensions

Face Width	48"	1219mm
Back Width	39"	991mm
Depth	24"	610mm
Height	24"	610mm
Face Area	8 sq ft	0.74 sq m
Setback	4.5°	2.0"/Unit
Weight	1400lbs	635Kg*

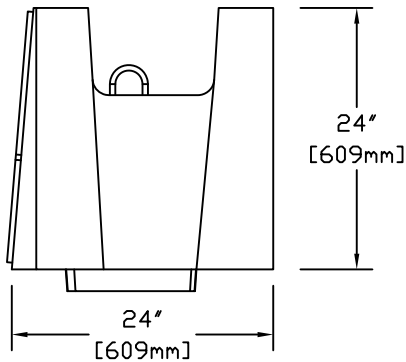

>>>SIDE VIEW

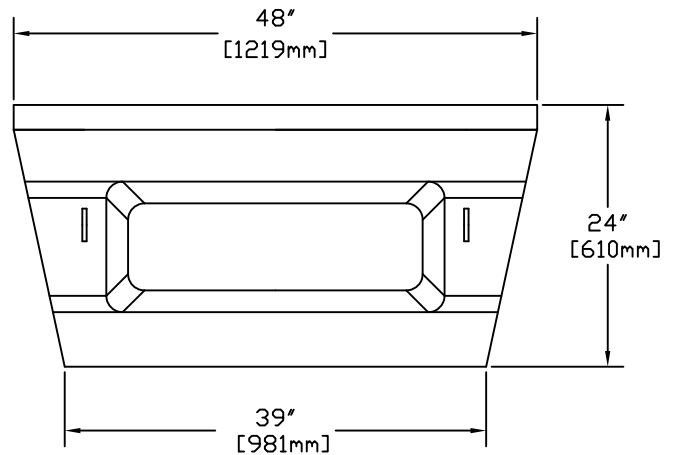

>>>TOP VIEW

*Weights may vary between producers

These preliminary details are intended solely to act as an aid when designing a wall. This drawing should not be used for final design or construction. Each site-specific wall should be certified and signed by a registered geotechnical engineer in the State or Province that it is being built. The accuracy and use of the details in this document are the sole responsibility of the user.