

MagnumStone Batter

>>> HALF HIGH BASE

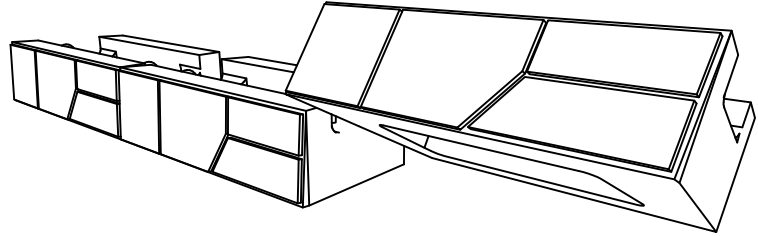

>>> ISOMETRIC BOTTOM VIEW

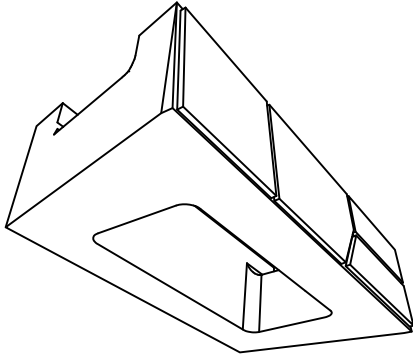
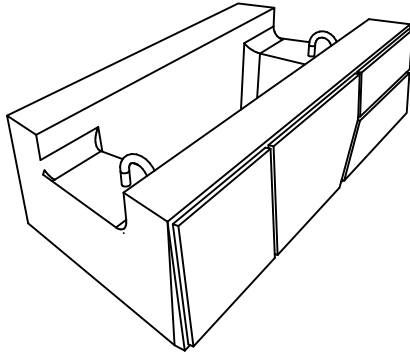

Dimensions

Face Width	48"	1219mm
Back Width	39"	991mm
Depth	12"	305mm
Height	12"	305mm
Face Area	4 sq ft	0.37sq m
Setback	4.5°	1.0"/Unit
Weight	725lbs	329Kg

>>> ISOMETRIC TOP VIEW

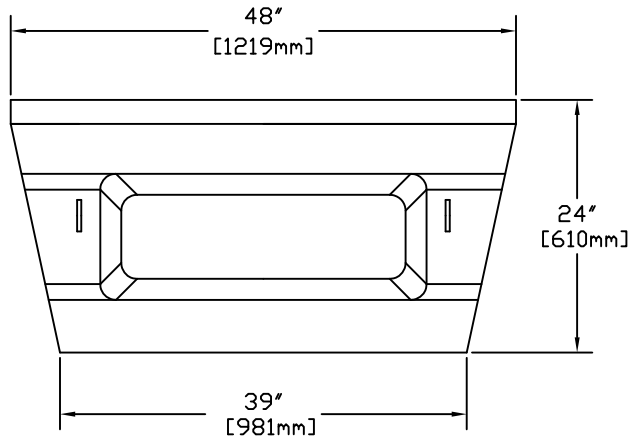
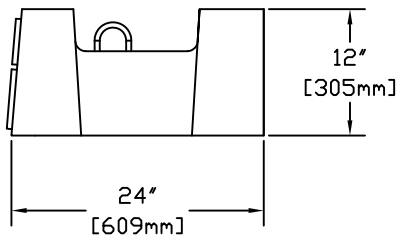

>>> SIDE VIEW

>>> TOP VIEW

*Weights may vary between producers



CORNERSTONE
WALL SOLUTIONS INC.

These preliminary details are intended solely to act as an aid when designing a wall. This drawing should not be used for final design or construction. Each site-specific wall should be certified and signed by a registered geotechnical engineer in the State or Province that it is being built. The accuracy and use of the details in this document are the sole responsibility of the user.